

INTRODUCTION



Thank you for choosing the JRC GPS sensor GPS124.

This manual describes Model GPS124, JRC GPS Sensor (Receiver) with Built-In Antenna and SBAS capability.

- To ensure correct operation of the GPS124, please read this Instruction Manual carefully before starting to use.
- This manual should be kept on hand to provide as quick reference whenever you need it.
- It will also help you if you come across any problems in its operation.

NOTES TO USERS

In order to ensure safe and correct use of the equipment, symbols in this manual and on the equipment itself alert the user to important operational precautions that could prevent personal injury or damage. The followings show such symbols and their meanings. Please read this manual carefully and take note of these symbols.

	WARNING	This symbol indicates warning items that, if ignored, may result in serious personal injury or even death.
	CAUTION	This symbol indicates cautionary items that, if ignored, may result in personal injury or physical damage.

Other Symbols and Their Meanings:

 This symbol indicates that the action is prohibited.
Prohibited

 This symbol indicates that the action must be taken.
Do This

SECTION 1

GENERAL INFORMATION

1.1 Function

By receiving GPS signals from up to twelve satellites, GPS124 sensor provides highly accurate position fixing.

Furthermore, the GPS124 provides data output conforming to IEC61162-1 or the NMEA0183 format, and it can be connected to various marine equipment such as radars, fish finders, and plotters.

1.2 Features

- SBAS function

The GPS124 can implement DGPS measurement by receiving the correction data from SBAS satellite (WAAS/EGNOS/MSAS), and can achieve the measurement of high accuracy than the GPS measurement.

- RAIM function

The accuracy of position fixes is self-tested by the equipment. (RAIM function)
This function assures higher reliability to the position fix than conventional method.

- Twelve-channel, twelve-satellite tracking, and all in view

Highly accurate position fixing is ensured by simultaneous tracking of up to twelve satellites by twelve channels.

- Built-In DGPS function

Simultaneous using the external beacon receiver provides DGPS position fixing, and high accuracy can be measured by the GPS measurement.

- Switching between IEC61162-1 (NMEA 0183 version 2.3), NMEA0183 versions 1.5 and 2.1

The data output conforms to IEC61162-1 or NMEA 0183, and version switching is possible.
This feature allows the unit to be connected with various types of marine equipment including radars, fish finders, and plotters.

1.3 Items Supplied

Table 1-1 indicates a listing of items that are included with your GPS124.

Table 1-1 Components of the GPS124

No.	Name	Model Name	Quantity	Notes
1	GPS Receiver	JLR-4340	1	Including 10m (33ft) cable with connector
2	Instruction Manual		1	Code: 7ZPNA4008
3	Warranty Card			
	Europe		1	Code: 7ZPBS2901C
	North America		1	Code: 7ZPBS2902E
	Asia/Oceania		1	Code: 7ZPBS2903C

SECTION 2

PARTS AND FUNCTIONS

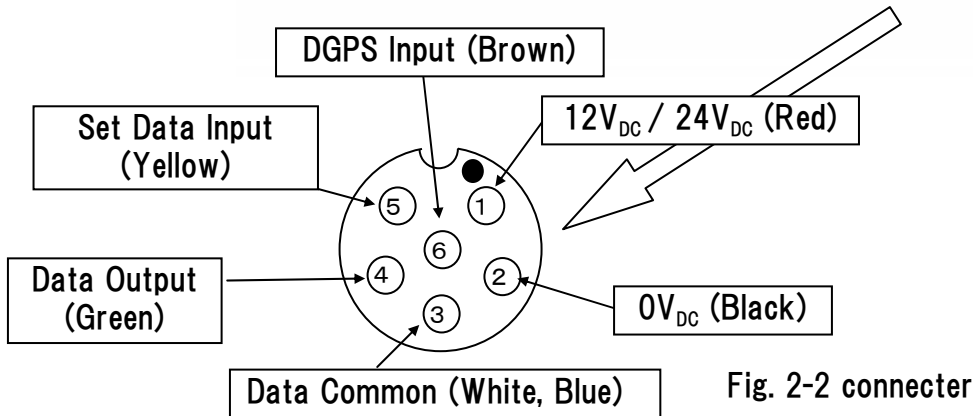
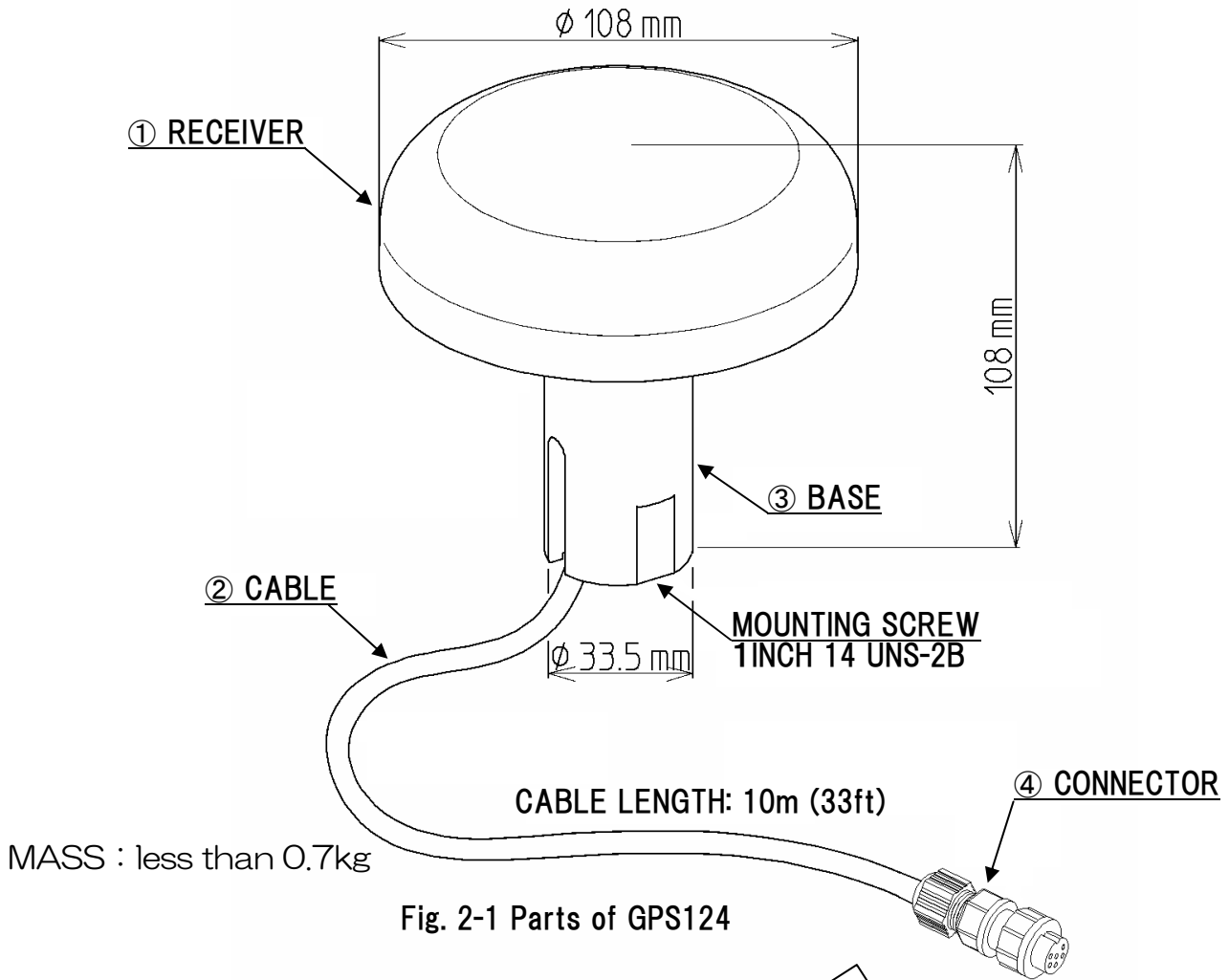

- ① RECEIVER: Receives GPS signals from up to twelve satellites and provides highly accurate position fixing.
- ② CABLE: Supplies DC power for the antenna and inputs/outputs data to a navigation equipment. 8-wire cable
- ③ BASE: Mount unit which conforms to 1" × 14 NPT standards. With this, the Receiver can be installed onto a 1-inch antenna mount or extension mast.
- ④ CONNECTOR: Hooks up the receiver to a navigation equipment. 6-pin

SECTION 3

INSTALLATION

3.1 Unpacking and Checking





Take out the GPS124 from the packing case carefully.

Check each item listed in Table 1-1 is contained in the case.

Save the case and the packing material until the equipment will be installed successfully.

In case the equipment is to be returned, kindly use the kept packing material.

3.2 Locating the Position for Installation

 CAUTION	
	Do not install the cable with tight bending, hard twist, kink, tension or strain. These deeds give the cable exterior and / or interior damage.
	Do not install this equipment in the place where an excessive vibration and a shock otherwise it will cause defective reception of GPS signals.
	Do not paint the outer cover of GPS124, receiver. Painting may cause poor receiving.
	Install the GPS124 where there is no obstacle, in order to ensure that GPS signals can be directly received from satellites without interference or reflection of signals from surrounding structures. Determine the best location that meets as many criteria as possible mentioned hereof.
<ol style="list-style-type: none">1. An open space, which allows uniform reception of satellite signals2. Far away from any high power transmission antennas3. Outside radar beams4. Away from the INMARSAT antenna by not less than 5 meters and outside the INMARSAT beam5. Away from the antenna of a VHF transmitter and a direction finder by not less than 3 meters6. Away from a Magnetic Compass by not less than 1 meter	
<p>If it is difficult to find an ideal site, select a place temporarily and install the equipment. Conduct a test to make sure that the proper performance can be obtained and then fix the equipment in position. A poor location could result in intermittent reception, which reduces the time of the position fix and therefore, its accuracy.</p>	

3.3 Installation Procedure

The base of the GPS124 is designed so that it can be installed on the navigation antenna mount unit or on an extension mast that conforms to 1" x 14 NPT standards. The bottom of the receiver is provided with a slot to allow the receiver cable to be pulled out to the side. This eliminates the need of pulling the cable through the center of an extension mast. If the cable is fed through the center of a mast, the cable connector will have to be removed.

Caution:

When turning the receiver, be careful not to damage the cable and the plastic top cover of the receiver. (See Figure. 3-1.)



Do not turn and grip the cover

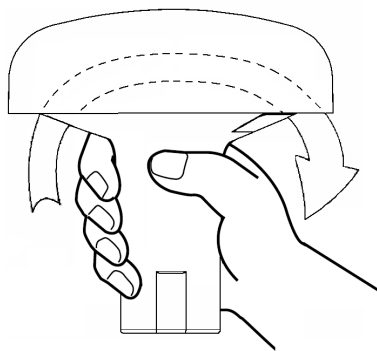

Grip the base to turn

Fig.3-1 Installation

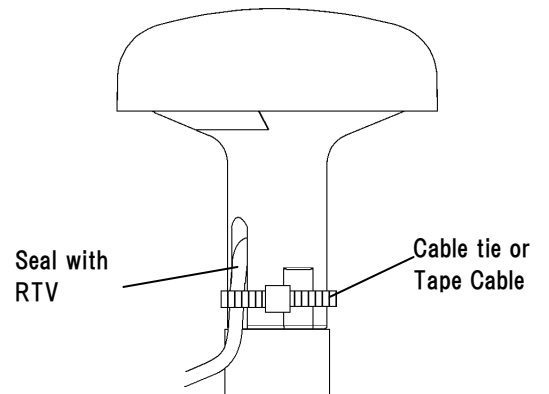



Fig. 3-2 Appearance

When the cable is fed internally through the extension mast, it is recommended that RTV silicon sealant be used to seal off the cable slot on the bottom of the receiver as a protection from the environment. If the cable is laid sideways through the slot, secure it in position to reduce the damage by vibration. Then seal the slot on the receiver bottom with the RTV silicon sealant. (See figure.3-2)



3.4 Cable connection

3.4.1 Connection to Navigation Equipment that can be connected directly

 CAUTION	
	When you connect the GPS124 to the navigation equipment that is possible to connect directly, confirm the type of connector and pin arrangement beforehand. If the possibility of direct connection with GPS124 is not described in the manual of the navigation equipment, confirm the all pin assignment. Incorrect pin connection may cause a damage of the equipment.

When the GPS124 is connected to directly connectable GPS navigation equipment, 12 V_{DC} is supplied from the equipment to the GPS124. In this case, connect the 6-pin connector to the plug where the GPS label is attached on the rear panel of the equipment.

3.4.2 Connection to Navigation equipment that cannot be connected directly

 CAUTION	
	Connect it taking care about the polarity of the power supply. The faulty wiring might damage the GPS124.
	GPS 124 is designed for the power supply of 12/24VDC. If the power supply of over 40V is fed to the equipment, It might be damaged.

Normally, the 12/24VDC power is supplied out of the DC power switchboard or main battery. As the normal current of the equipment is approximately 0.1A, it is recommended using a fuse not exceeding 2A in the power line.

When the initialization is not provided, leave pin 5 open.

When the DGPS correction data is not applied, pin 6 open.

Fig. 3.3 shows the connection for NMEA 0183 data output with the equipment that cannot be connected directly.

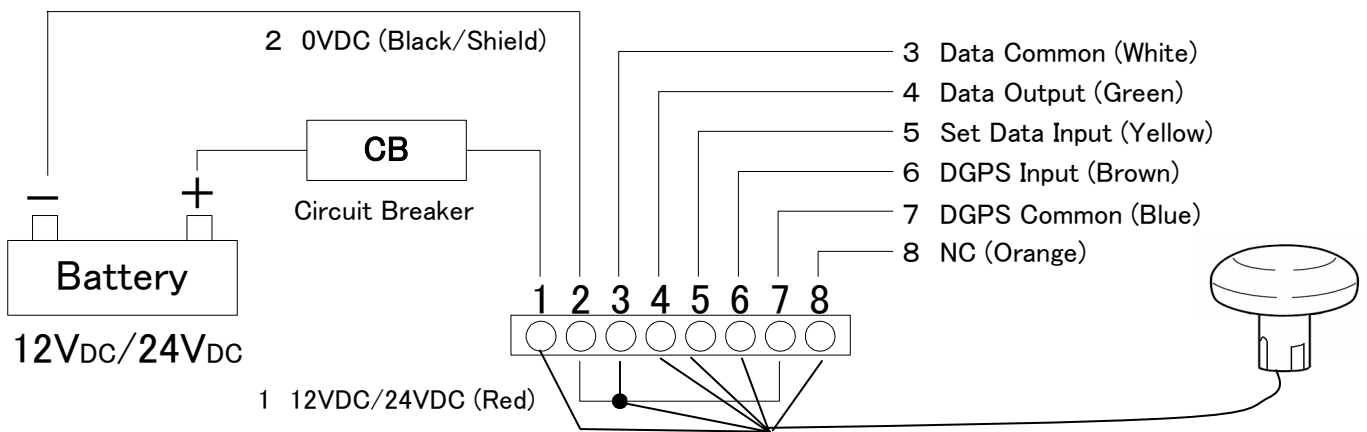
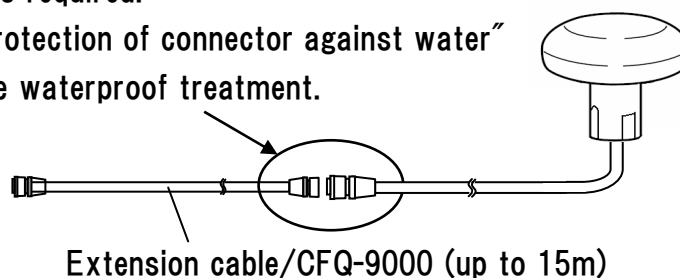

Fig. 3-3 Indirectly connectable Navigation Equipment

3.4.3 Extend to cable

Waterproof treatment is required.

Refer to "Attention : Protection of connector against water" on the next page please waterproof treatment.



Attention : Protection of connector against water

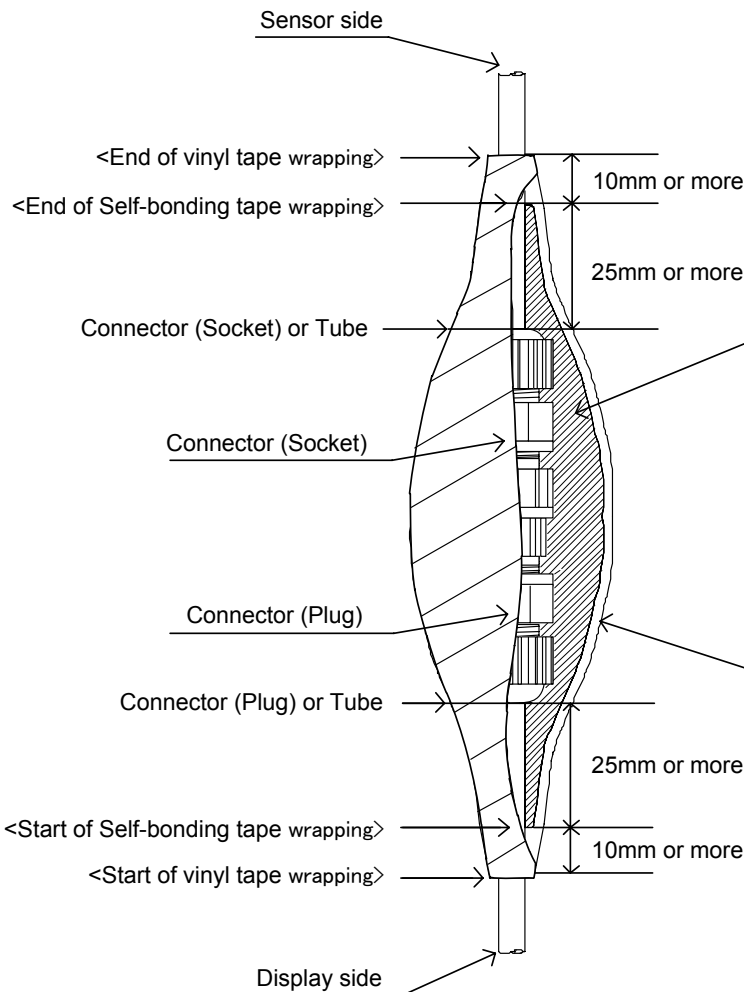
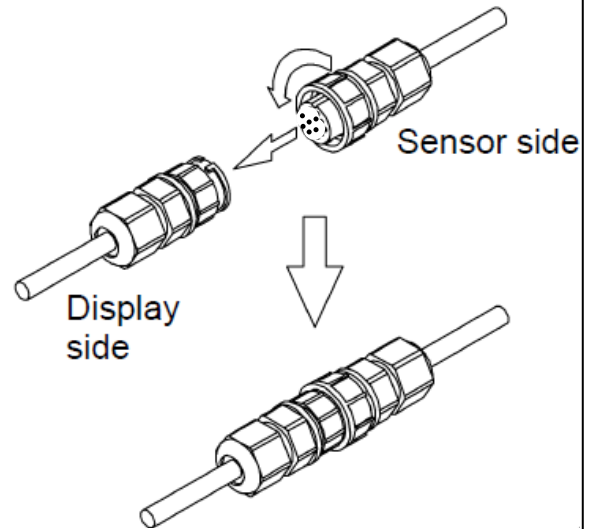

Self-bonding tape

Take a proper length of tape off the role. While pulling in accordance with tape manual, wrap it around the connector with one half of it overlapped so that the wrapped tape may form **three layers**. However, portions between the connector and cable have different diameters. This portion apply tape more than the other portions. When the tape has been wrapped, press to hold by hand.

Protective PVC tape (vinyl tape)

Taking care not to give tension to the tape, wrap the tape around the connector with one half of it overlapped so that the wrapped tape may form **three layers**.

3.5 NMEA Version Switching



The GPS124 has the function to switch the NMEA output versions 1.5, 2.1, and 2.3. When the equipment is shipped from the factory, the NMEA output version is set to the version 1.5. If you want to change the version to 2.1 or 2.3, please carry out the following procedure:

1. Connect pin 4 and pin 5 of the connector.
2. Turn on the GPS124 and wait for more than 30 seconds.
3. Turn off the GPS124 and open the connection between pin 4 and pin 5.

(NMEA 0183 data version is switched to 1.5, 2.1, and 2.3 sequentially.)

SECTION 4

AFTER-SALES SERVICE

 WARNING	
	Do not remove the cover of the GPS124 otherwise it may cause fire, electric shock, and malfunction. It may also cause poor waterproofing.

If the GPS124 appears to be defective, check the connection again. If the equipment still appears faulty after that, stop using the equipment and contact our representative or our sales office directly.

During the warranty period, JRC representative or our company replaces your GPS124 sensor free of charge. This warranty does not cover damage, which has occurred in transit, or results from alteration, accident, misuse or abuse.



JRC needs to have the following information:

- Product name, model name, serial number, and purchase date
- Detailed failure conditions
- Name of the company/organization, address, and telephone number
- Contact name

For further information on after-sales service, please contact JRC representative, JRC branch office or sales office. For details, see "Place of Contact" (page 8).

SECTION 5

DISPOSAL

 WARNING	
	Do not throw lithium battery into the fire and overheat it. It may cause an explosion and ignition.

Disposal of the GPS124

The GPS124 contains a lithium battery for memory backup.

Observe all the laws and regulations concerned when you dispose of the GPS receiver.

SECTION 6

SPECIFICATIONS

Receiver type:	Multichannel (12CH, SBAS 1CH) all in view
Accuracy:	13m 2DRMS (C/A code, HDOP \leq 4, SA off) 7m 2DRMS (SBAS corrected) 0.1knots RMS (steady state)
Geodetic datum:	46 (selectable, default*: WGS-84)
Data input:	Initial input, GPS correction data (RTCM SC-104 ver.2.0, Type 1,2,7,9)
Data output:	IEC61162-1 or NMEA0183 compliance (selectable, default*: NMEA0183 ver.1.5) IEC61162-1 (NMEA0183 ver.2.3) GGA, RMC, VTG, ZDA, DTM, GBS, GNS NMEA0183 ver.2.1 GGA, RMC, GLL, VTG, DTM NMEA0183 ver.1.5 GGA, RMC, GLL, VTG
Operating temperature:	-25°C to +70°C
Storage temperature:	-40°C to +85°C
Vibration:	IEC60945 compliance
Waterproof:	IEC60945/USCG CFR-46 compliance
EMC:	IEC60945 compliance
Input voltage:	12/24VDC +30%, -10%
Power consumption:	Less than 1.5W
Dimensions, Mass:	108H \times 108 ϕ (mm), less than 0.7kg

* When the Lithium battery runs out, the settings are restored to the default values. In addition, it will take about a minute for position fix. The battery life expires in about 10 years under the normal use condition, but it may differ depending on the environment or use conditions.

电子信息产品有害物资申明
日本无线株式会社

Declaration on toxic & hazardous substances or elements
of Electronic Information Products
Japan Radio Company Limited

有毒有害物质或元素的名称及含量
(Names & Content of toxic and hazardous substances or elements)

形式名(Type): JLR-4340

名称(Name): GPS Sensor

部件名称 (Part name)	有毒有害物质或元素 (Toxic and Hazardous Substances and Elements)					
	铅 (Pb)	汞 (Hg)	镉 (Cd)	六价铬 (Cr ⁶⁺)	多溴联苯 (PBB)	多溴二苯醚 (PBDE)
GPS接收器 (Antenna)	×	○	×	×	×	×
船内装置(Inboard Unit) ·显示装置(Display Unit) ·信号处理装置 (Processing Unit)	—	—	—	—	—	—
外部设备(Peripherals) ·选择(Options) ·电线类(Cables) ·手册(Documentts)	×	○	×	×	×	×
<p>○:表示该有毒有害物质在该部件所有均质材料中的含量均在SJ/T11363-2006 标准规定的限量要求以下。 (Indicates that this toxic, or hazardous substance contained in all of the homogeneous materials for this part is below the requirement in SJ/T11363-2006.)</p> <p>×:表示该有毒有害物质至少在该部件的某一均质材料中的含量超出SJ/T11363-2006 标准规定的限量要求。 (Indicates that this toxic or hazardous substance contained in at least one of the homogeneous materials used for this part is above the limit requirement in SJ/T 11363-2006.)</p>						

RE: 中华人民共和国电子信息产品污染控制管理办法

Management Methods on Control of Pollution from Electronics Information Products of the People's Republic of China

PLACE OF CONTACT

For further information,contact:

Japan Radio Co.,Ltd.

Since 1915

URL <http://www.jrc.co.jp>

Marine Service Department

Telephone: +81-3-3492-1305

Facsimile: +81-3-3779-1420

e-mail: tmsc@jrc.co.jp

SEATTLE Branch

Telephone: +1-206-654-5644

Facsimile: +1-206-654-7030

e-mail: marineservice@jrcamerica.com

ALPHATRON

Alphatron Marine BV

URL <http://www.alphatronmarine.com>

Rotterdam (Head office)

Alphatron Marine B.V.

Telephone: +31 (0)10-453 4000

Facsimile: +31 (0)10-452 9214

e-mail: service@alphatronmarine.com

Singapore Branch

Alphatron Marine Systems Pte Ltd

Telephone: +65 6863 0335

Facsimile: +65 6863 3305

e-mail: service@alphatronmarinesystems.com